

316 352 600 001 / 316 363 600 001

ATTENTION : (pour connaître les caractéristiques d'utilisation consulter la carte grise).

Installé suivant nos recommandations, cet attelage vous donnera entière satisfaction. Nous dégageons toute responsabilité en cas de transformation ou d'utilisation illicite de celui-ci

FR

ACHTUNG: (Nutzungsmerkmale : siehe Fahrzeugschein)

Diese Anhängervorrichtung wird Sie voll zufrieden stellen, wenn Sie unsere Montageanleitung befolgen. Im Falle der unerlaubten Veränderung oder des unerlaubten Gebrauchs lehnen wir jede Haftung ab.

DE

PLEASE NOTE : (to familiarise yourself with the operating characteristics refer to the log).

If this tow bar is fitted in accordance with our recommendations it will give a completely satisfaction. We cannot accept any responsibility in the event of changes to or improper use of this item.

EN

BEMÆRK : (for yderligere oplysninger om anvendelsesforhold henvises der til registreringsattesten)

Hvis dette anhængertræk monteres i henhold til vores anvisninger, vil det være til din fulde tilfredshed. Vi fralægger os ethvert ansvar ved ulovlig ændring eller brug af anhængertrækket.

DA

ΠΡΟΣΟΧΗ : (για να πληροφορηθείτε τα χαρακτηριστικά χρήσης συμβουλευτείτε την γκριζα κάρτα)

Εγκατεστημένο σύμφωνα με τις συστάσεις μας, αυτό το σύστημα ρυμούλκησης θα σας ικανοποιήσει πλήρως. Απεκδύομεθα πάσης ευθύνης σε περίπτωση μετατροπής ή παράνομης χρήσης αυτού.

EL

ATENCIÓN: (para conocer las características de utilización, consultar el permiso de circulación)

Instalado siguiendo nuestras recomendaciones, este enganche le dará total satisfacción. No asumiremos ninguna responsabilidad en caso de que haya sido transformado o utilizado ilícitamente.

ES

UWAGA (charakterystyki użytkowania należy sprawdzić w dowodzie rejestracyjnym)

Dyszel holowniczy będzie funkcjonował we właściwy sposób po zainstalowaniu go zgodnie z zaleceniami. Nie ponosimy żadnej odpowiedzialności w przypadku wprowadzenia zmian lub niedozwolonego użycia

PL

HUOMIO: (käyttöominaisuuksiin tutustumiseksi on katsottava rekisteriotetta)

Suosittelun mukaan asennettuna tämä vetokoukku täyttää odotuksesi.

Emme ota vastuuta, jos laitetta muutetaan tai käytetään ohjeiden vastaisesti.

FI

ATTENZIONE : (per conoscere le caratteristiche d'uso consultare il libretto di ircolazione)

Installato seguendo le nostre raccomandazioni, questo gancio da traino vi lascerà completamente soddisfatti. Respingiamo ogni responsabilità in caso di trasformazione o utilizzo illecito dello stesso.

IT

LET OP : (voor gebruikkenmerken het kentekenbewijs raadplegen)

Indien u de koppeling volgens onze aanbevelingen heeft geïnstalleerd, zal het u tot volle tevredenheid stemmen. Wij stellen ons niet aansprakelijk in geval van wijziging of onrechtmatig gebruik.

NL

ADVARSEL: (for kunnskap om bruksegenskapene, se vognkortet)

Ved å installere innretningen i samsvar med våre anbefalinger vil du få maksimalt utbytte av dette tilhengerfestet. Vi fraskriver oss alt ansvar hvis tilhengerfestet endres eller brukes på ulovlig måte.

NO

POZOR: (užívateľské charakteristiky naleznete v technickém průkazu)

Tažné zařízení instalované dle našich doporučení vás plně uspokojí. V případě přestavby nebo neoprávněného užívání se zbavujeme veškeré odpovědnosti

CZ

WARNING: (Läs igenom registreringsbeviset för att ta reda på rådande användningsvillkor)

Om du monterar produkten enligt våra anvisningar kommer du uppnå bästa möjliga resultat. Vi avsäger oss allt ansvar i de fall kunden inte följt våra anvisningar fullt ut.

SV

316352600001 (SI 204)

316363600001 (SI 203)

SCENIC 2

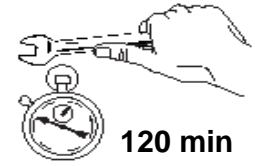
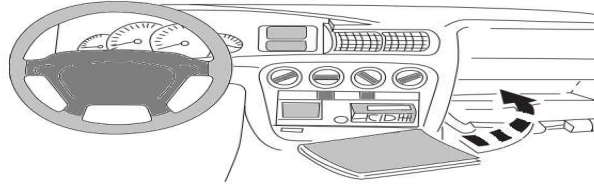
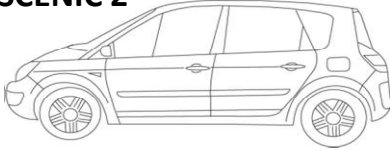

120 min

SCENIC 3

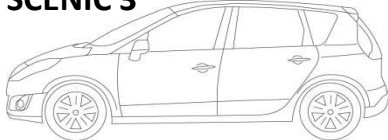

8,67 KN

SI 203

e24*55R*01 0321

SI 204

e24*55R*01 0322

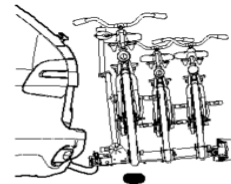

3 MAXI

60 Kg MAXI



MEGANE 2

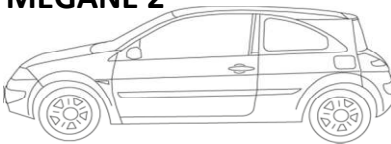

MEGANE 2

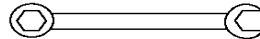
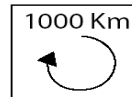
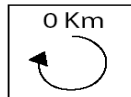
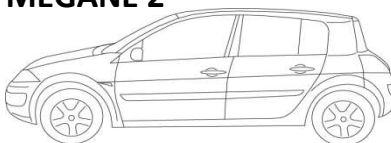

30 Kg MAXI

MEGANE 3

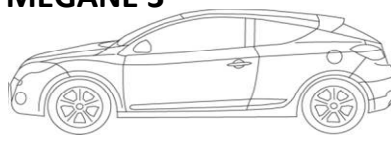

MEGANE 3

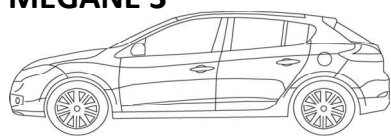

1500 Kg



75 kg



REF. WESTFALIA : 350030600001

REF. SIARR : 8570

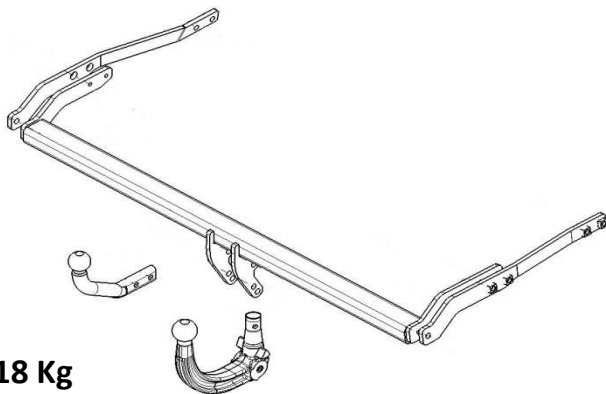

18 Kg



21 Kg



16 - 17 - 18 - 19



18 - 19







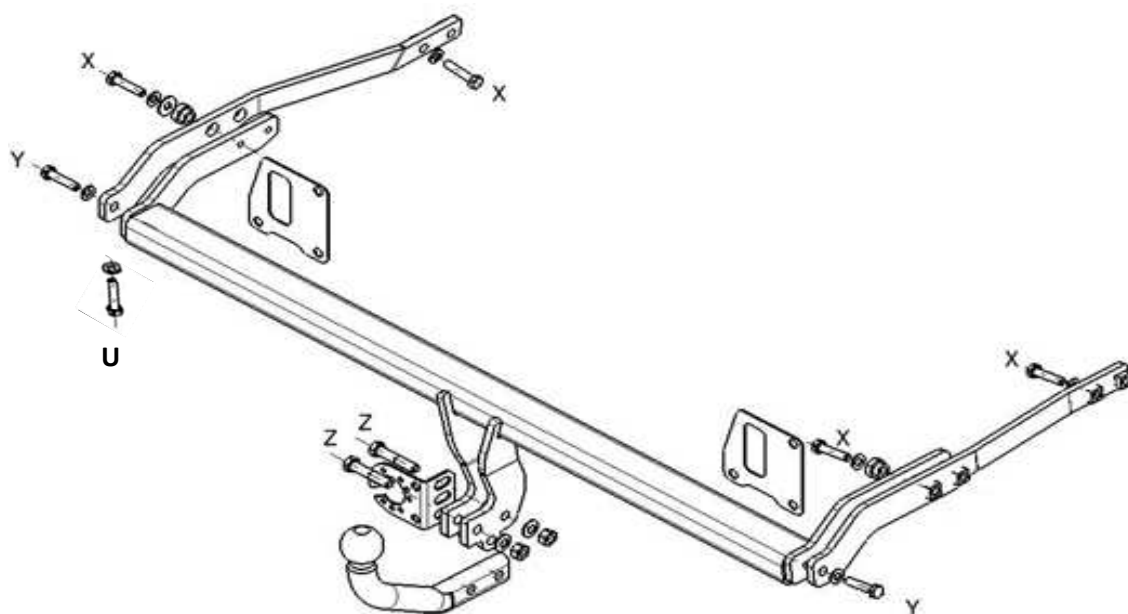

13









316 352 600 001



X	 HM 10 x 45 Cl 8.8	4
	 L10 / 27 x 3	4
	 CS 10	4
	 25 / 18 / 10	2





Y	 HM 10 x 45 Cl 8.8	2
	 CS 10	2

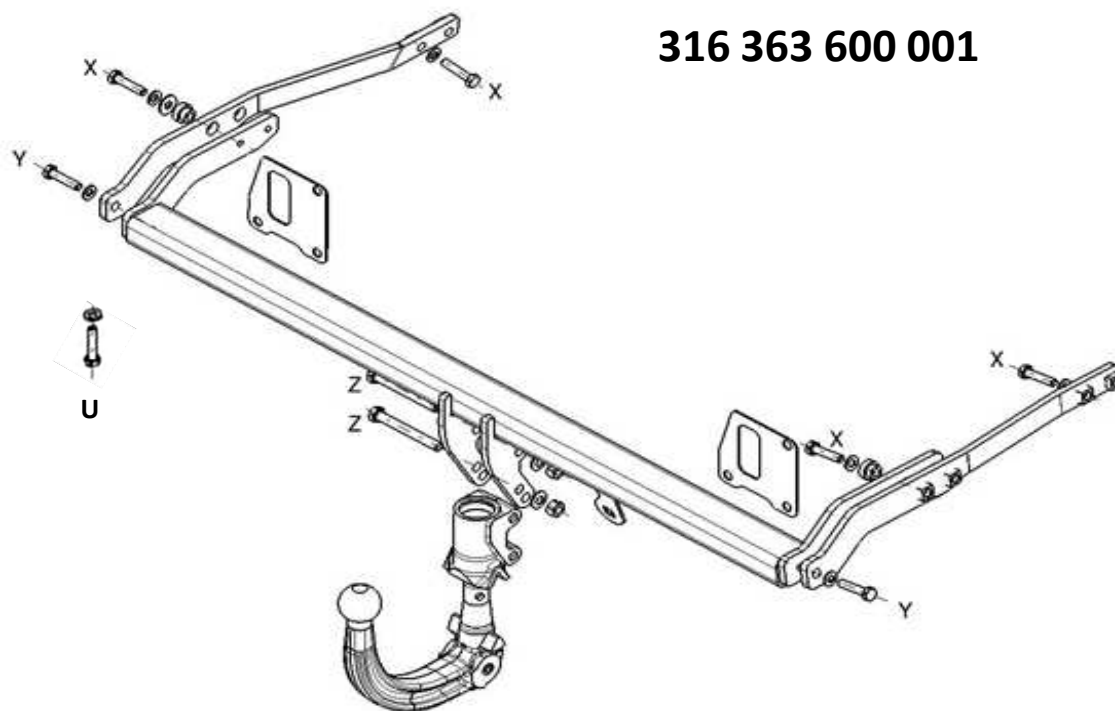

Z	 HM 12 x 60 Cl 8.8	2
	 M12 Cl8	2
	 CS 12	2
	 L 12 / 27	1





U	 HM 8 x 30 Cl 8.8	1	
	 CS 8	1	



316 363 600 001



X	 HM 10 x 45 Cl 8.8	4
	 L10 / 27 x 3	4
	 CS 10	4
	 25 / 18 / 10	2

Y	 HM 10 x 45 Cl 8.8	2
	 CS 10	2

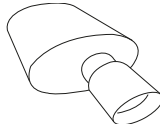
Z	 HM 12 x 100 Cl 10.9	2
	 M12 Cl10	2
	 CS 12	2
	 L 12 / 27	1

U	 HM 8 x 30 Cl 8.8	 1
	 CS 8	1

01

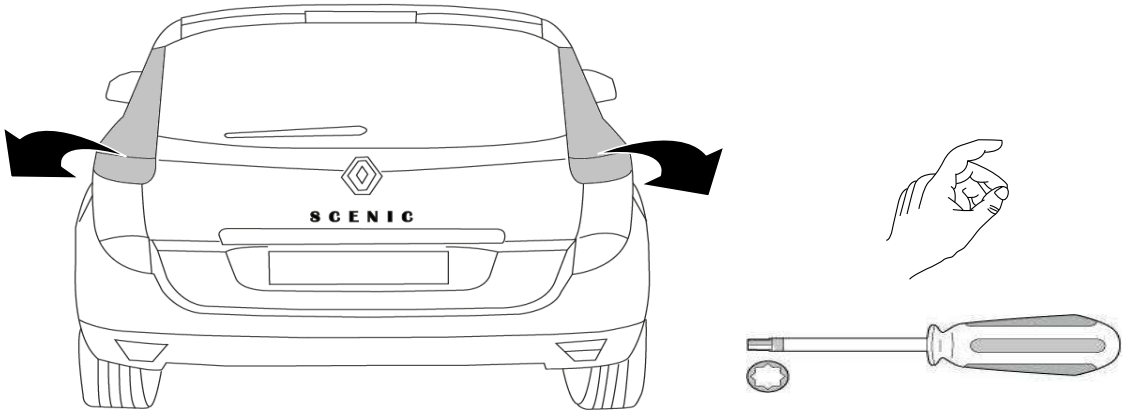

02

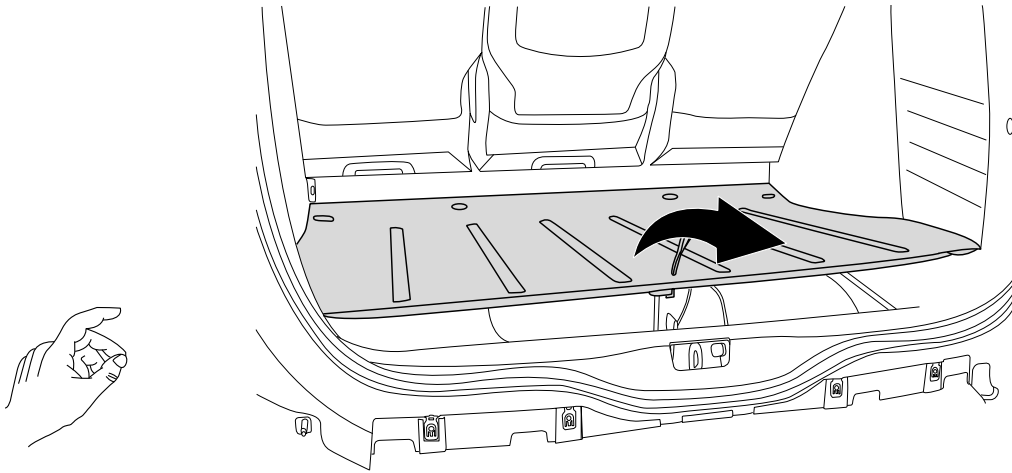

03

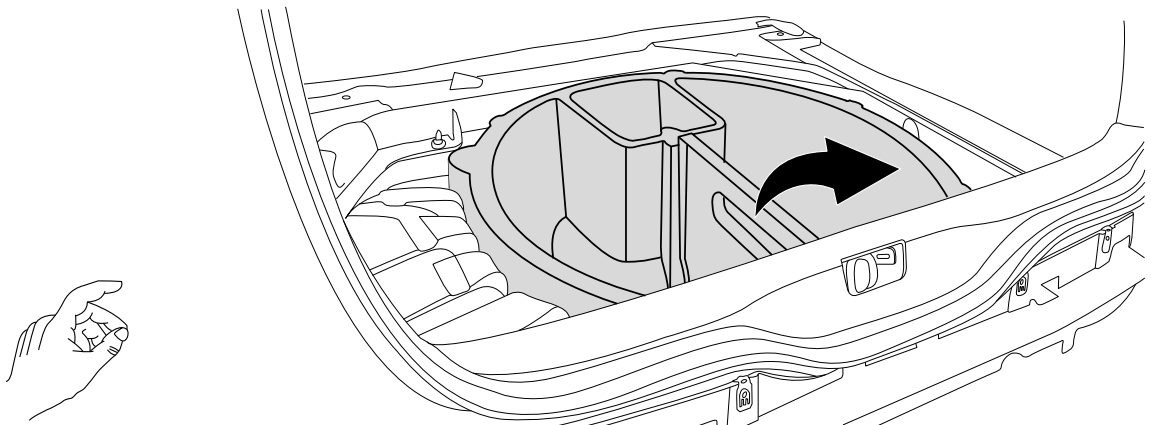

04

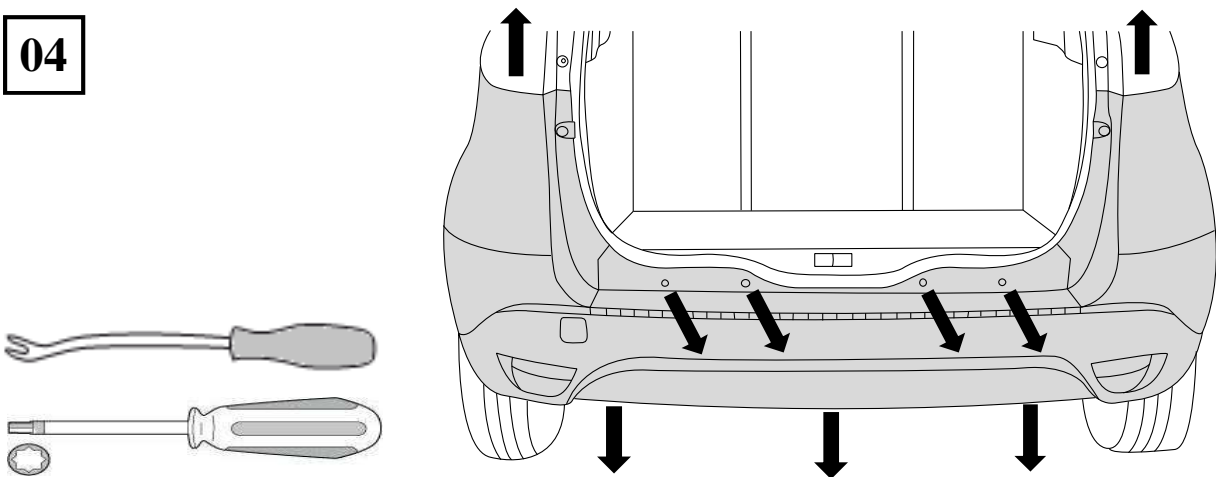

05

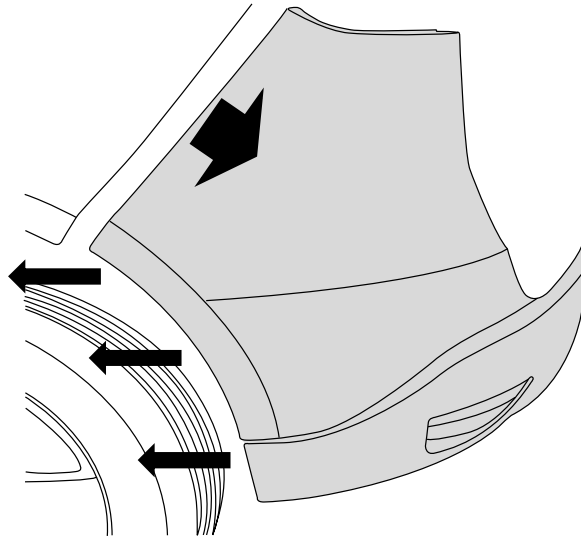
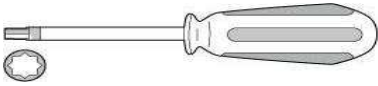

06

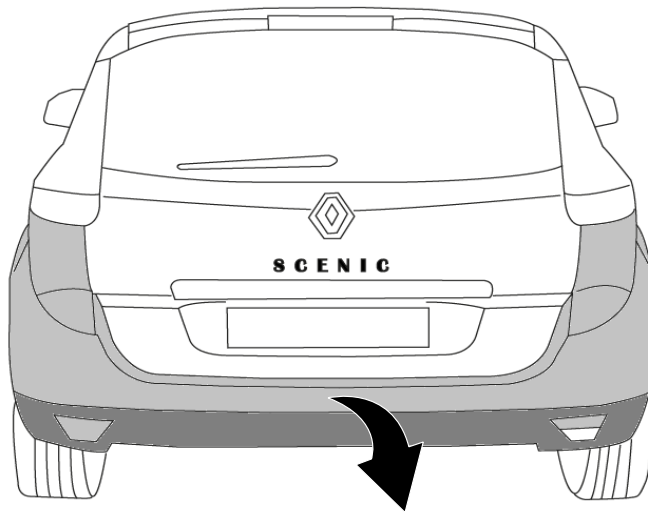
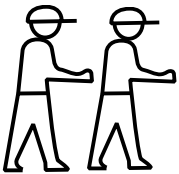

07

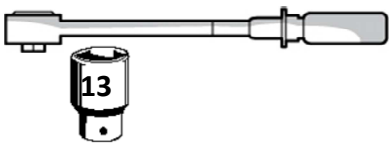
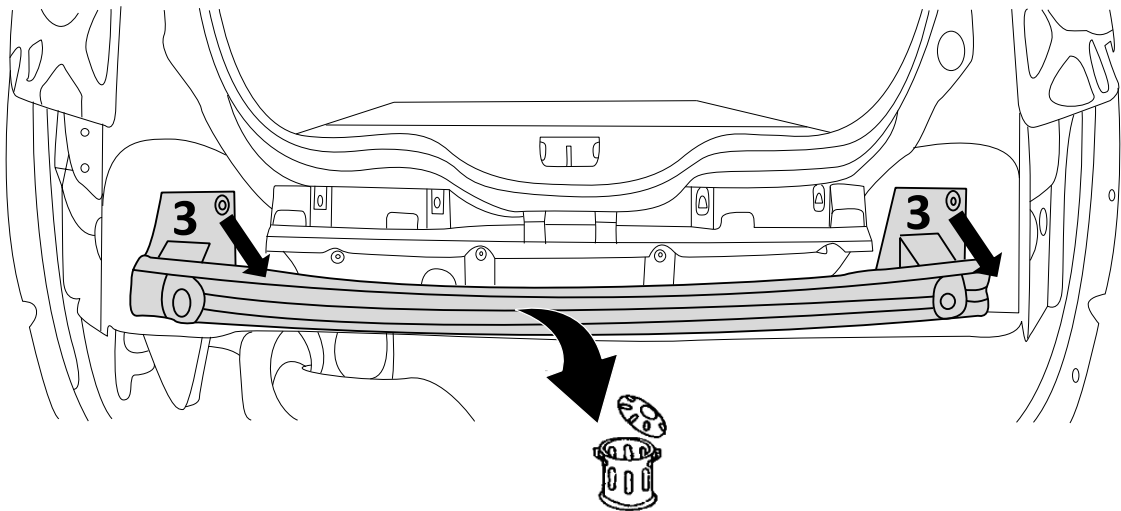

08

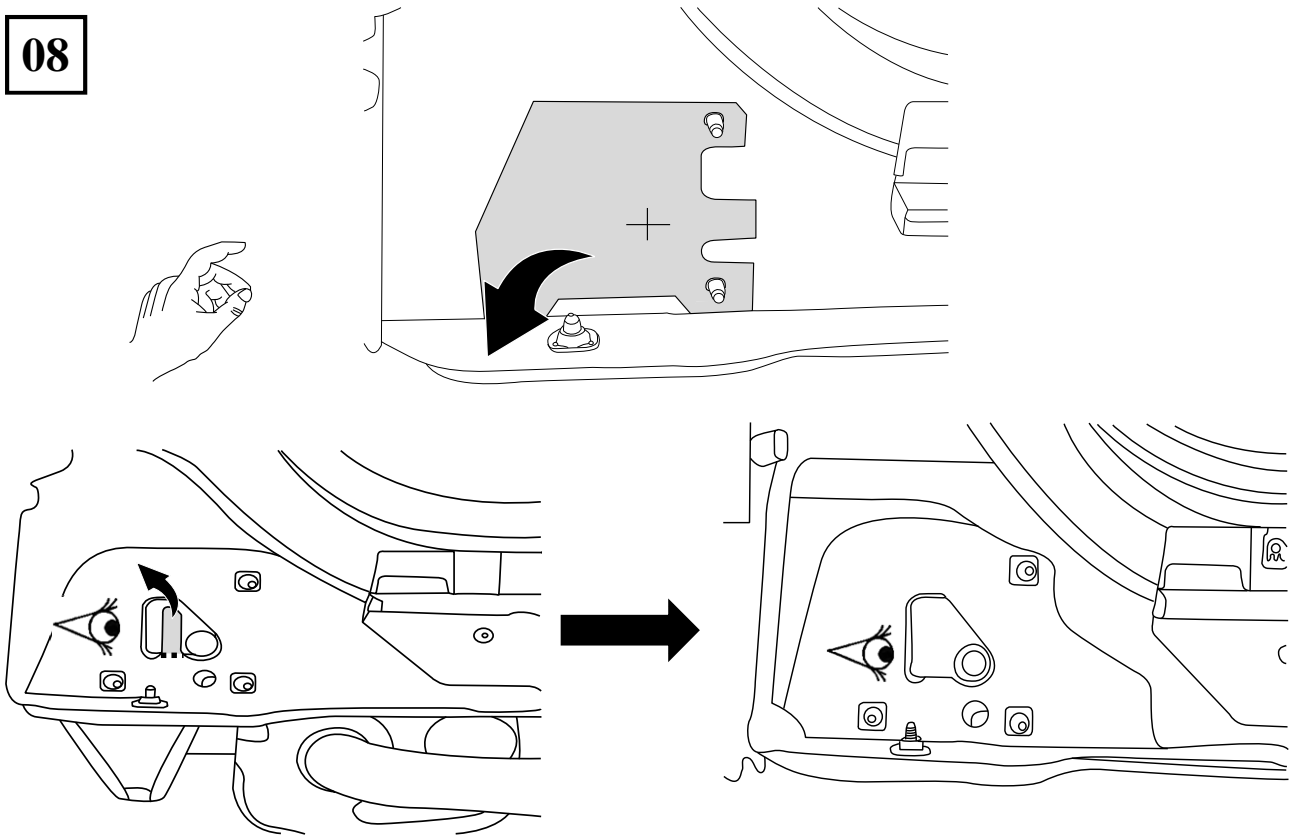

09

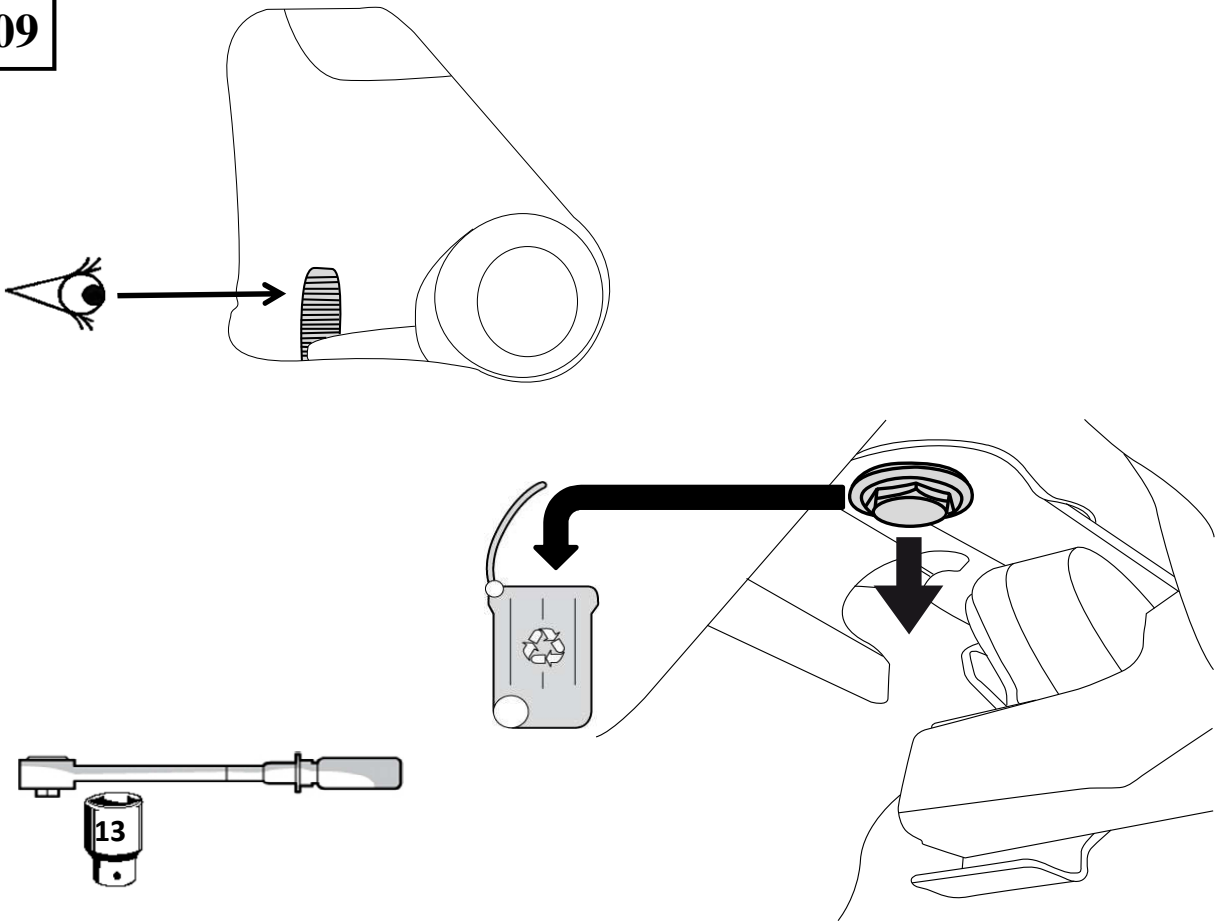

10

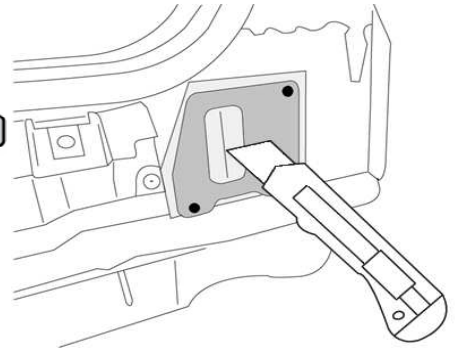
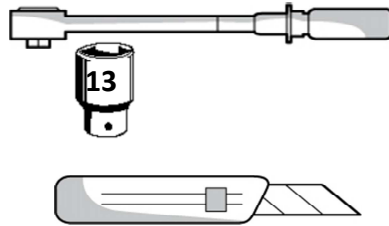
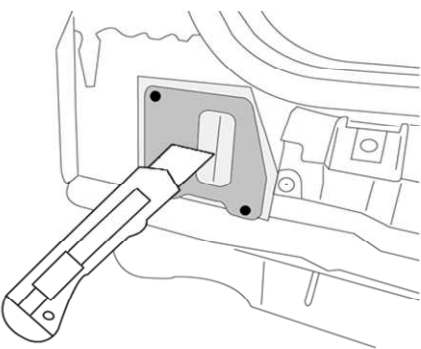
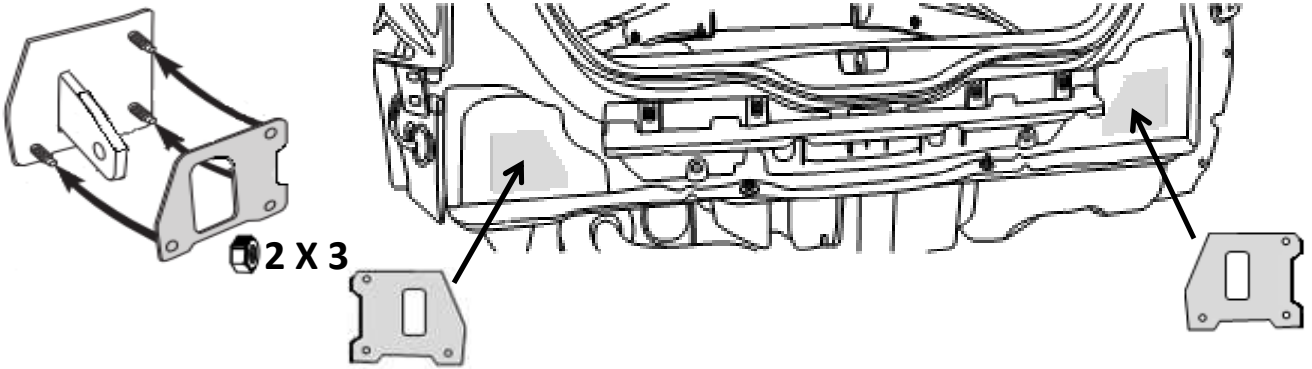
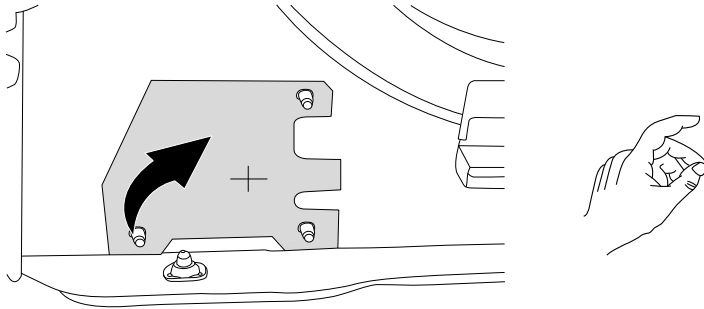

11

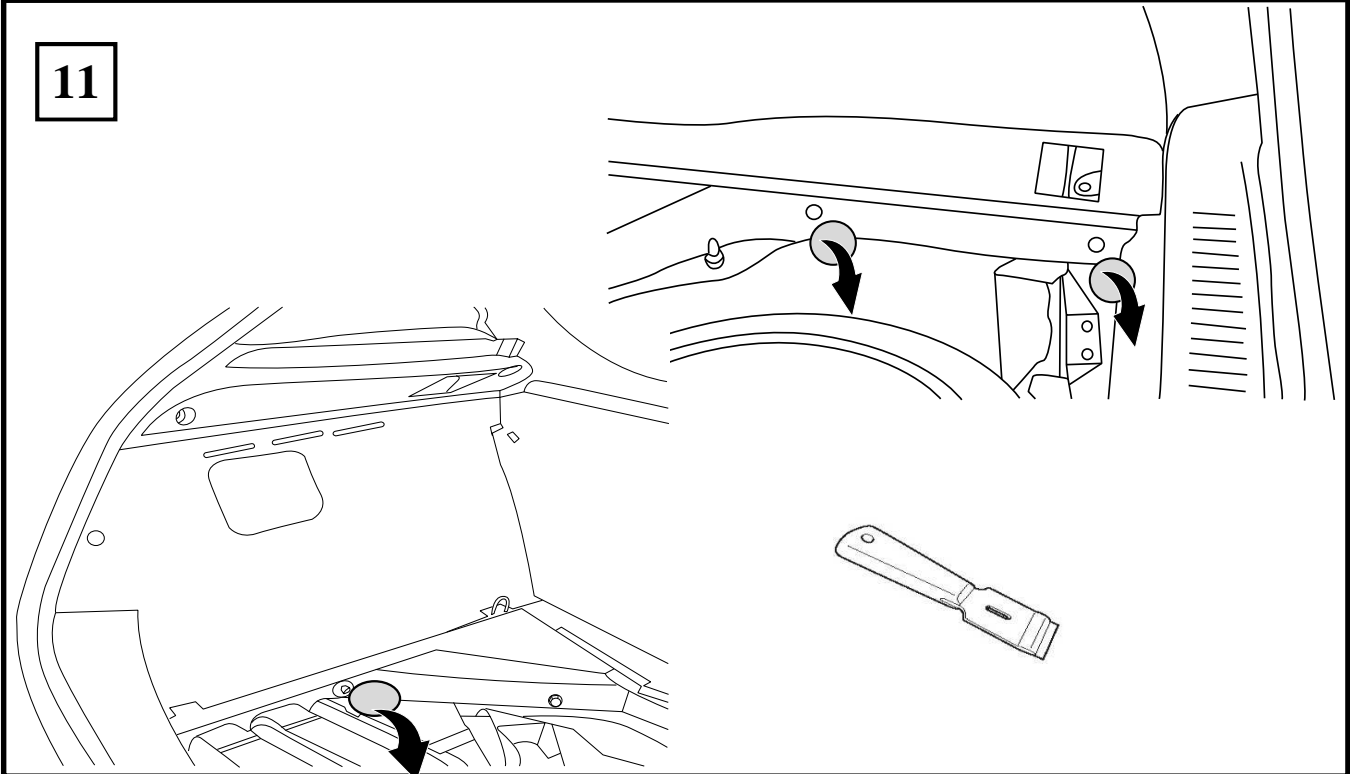

12

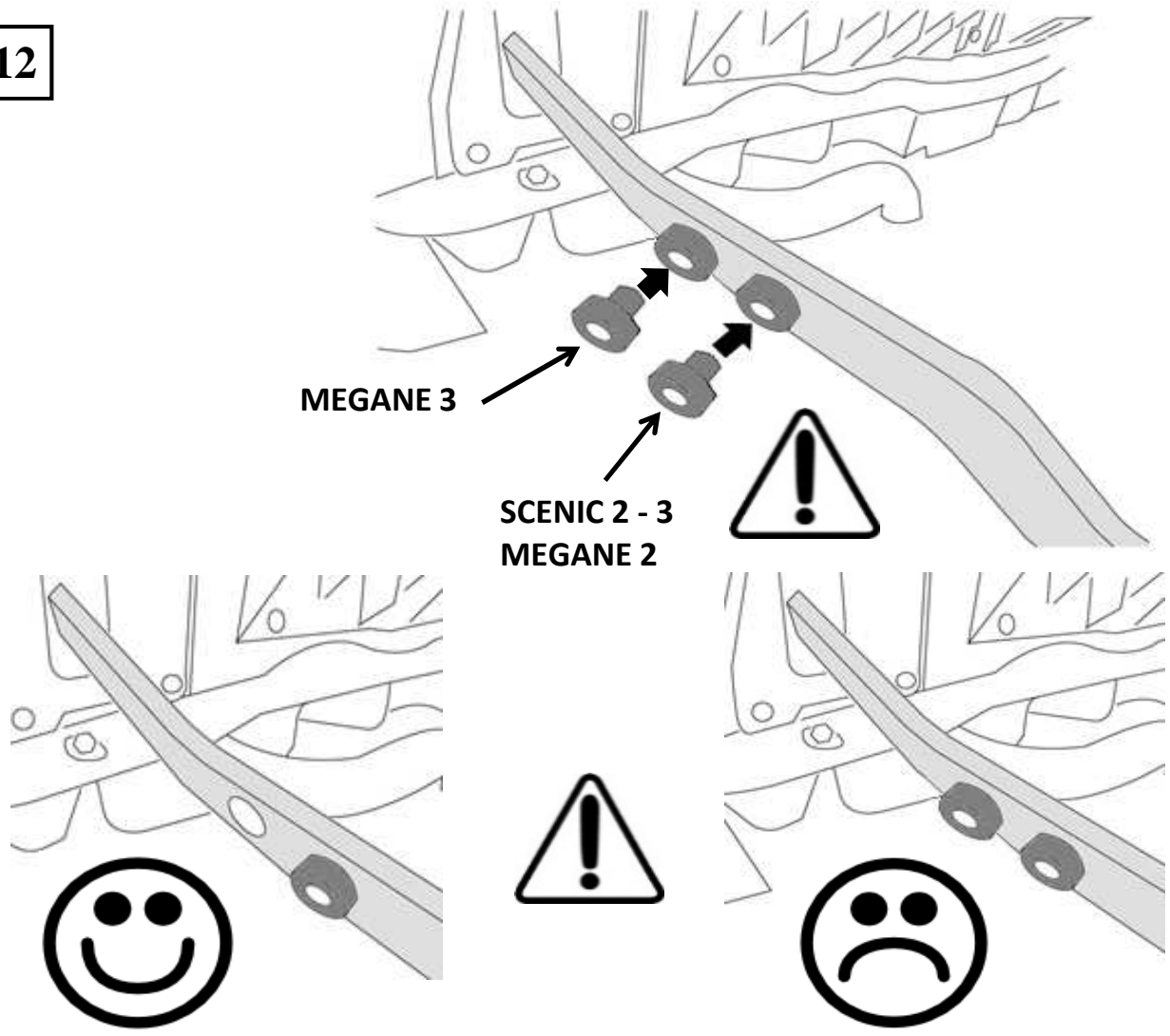

13

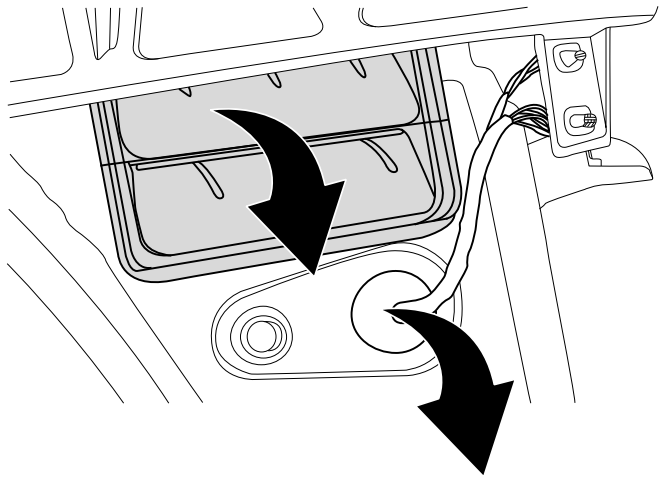
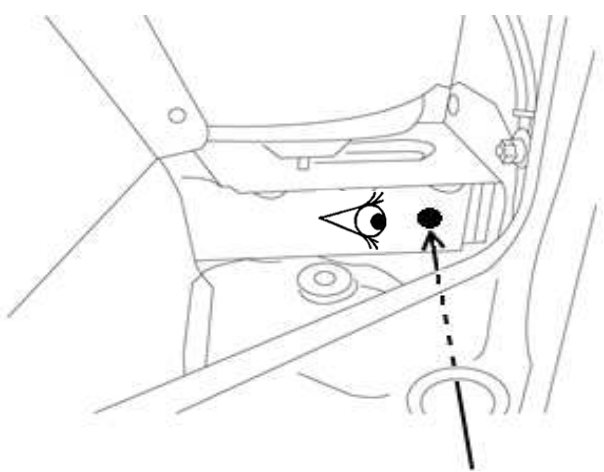
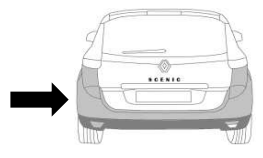

14

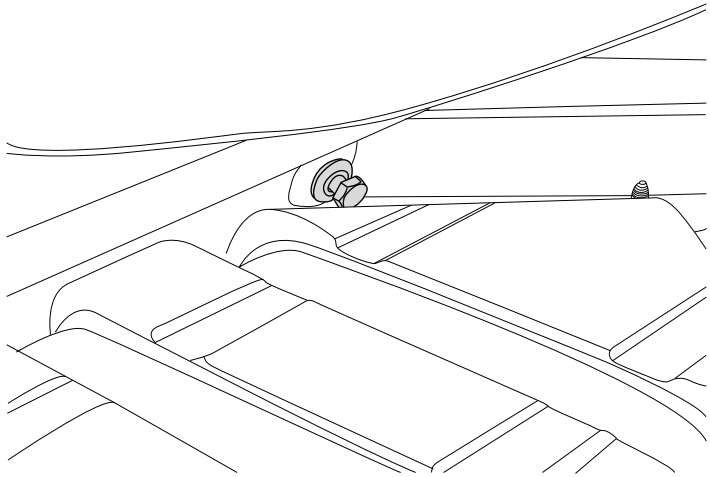

15

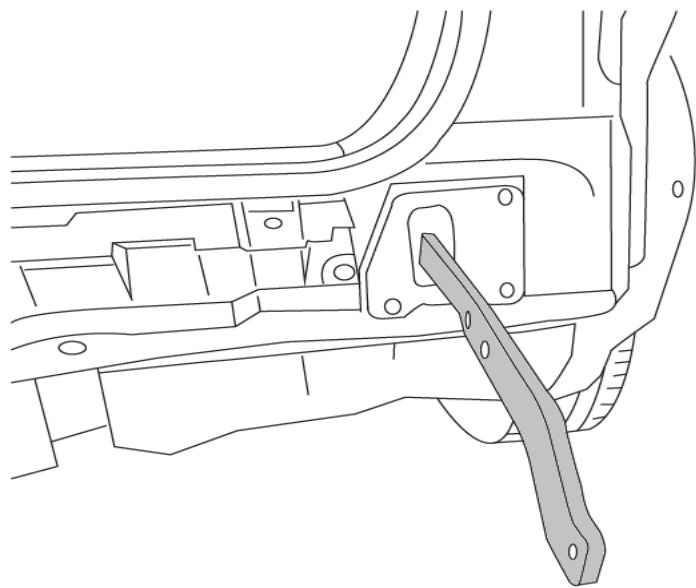

16

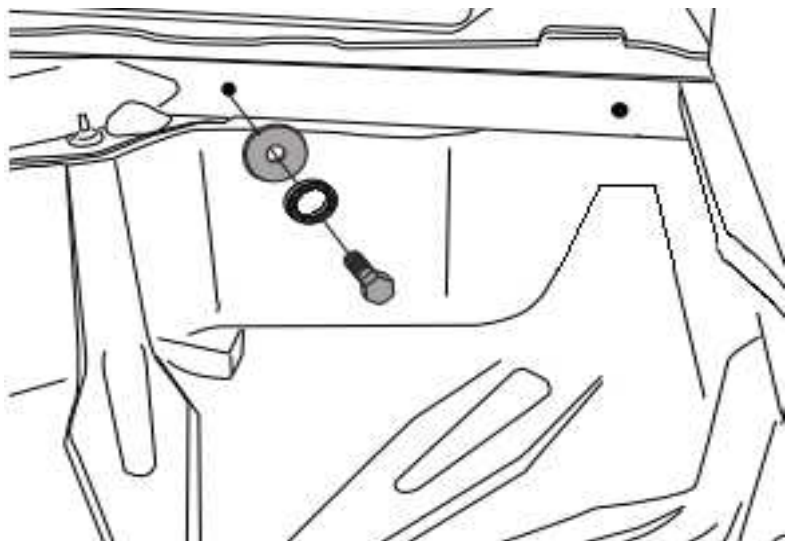

17

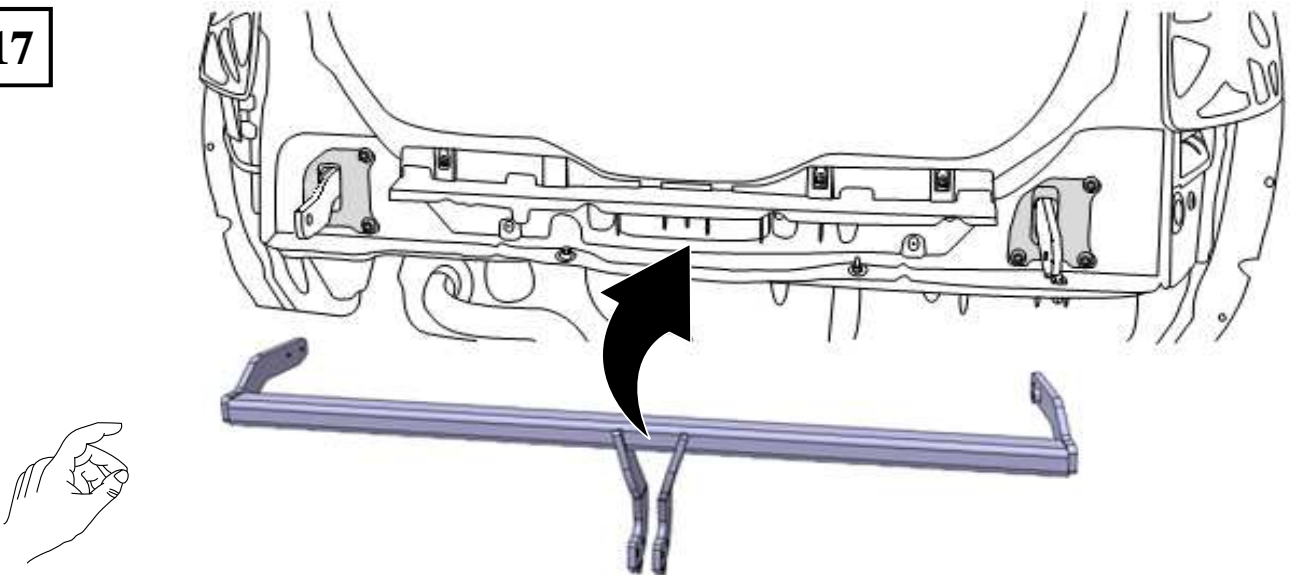

18

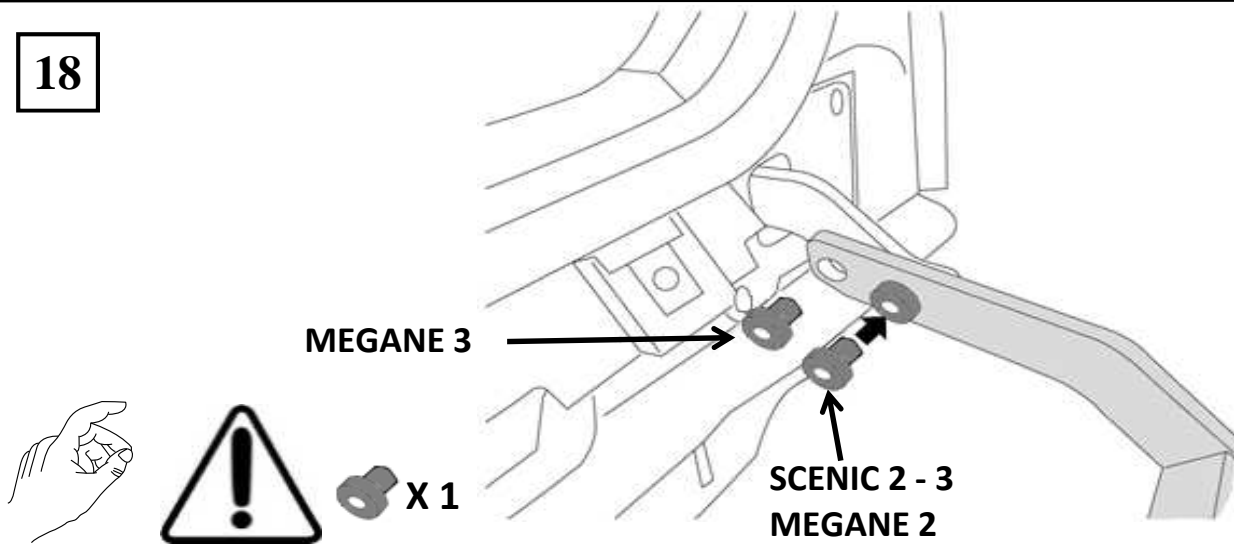

19

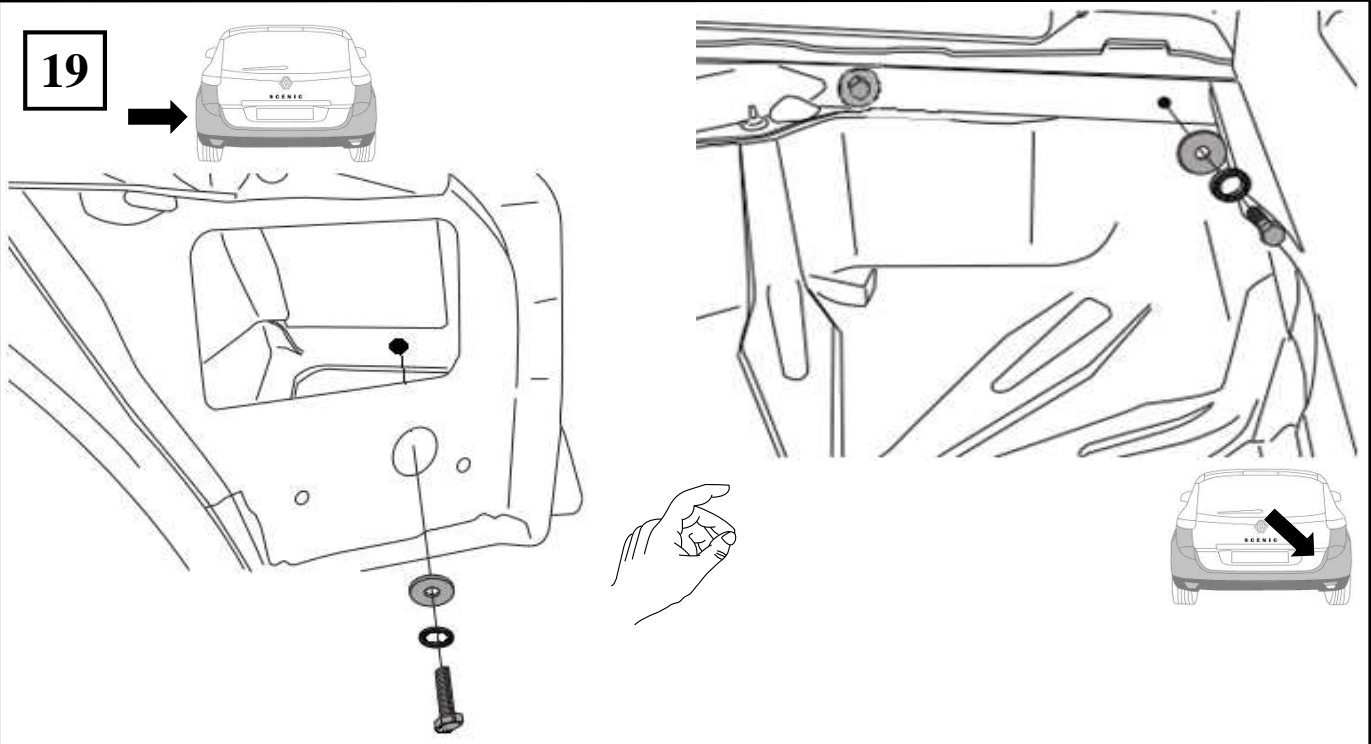

20

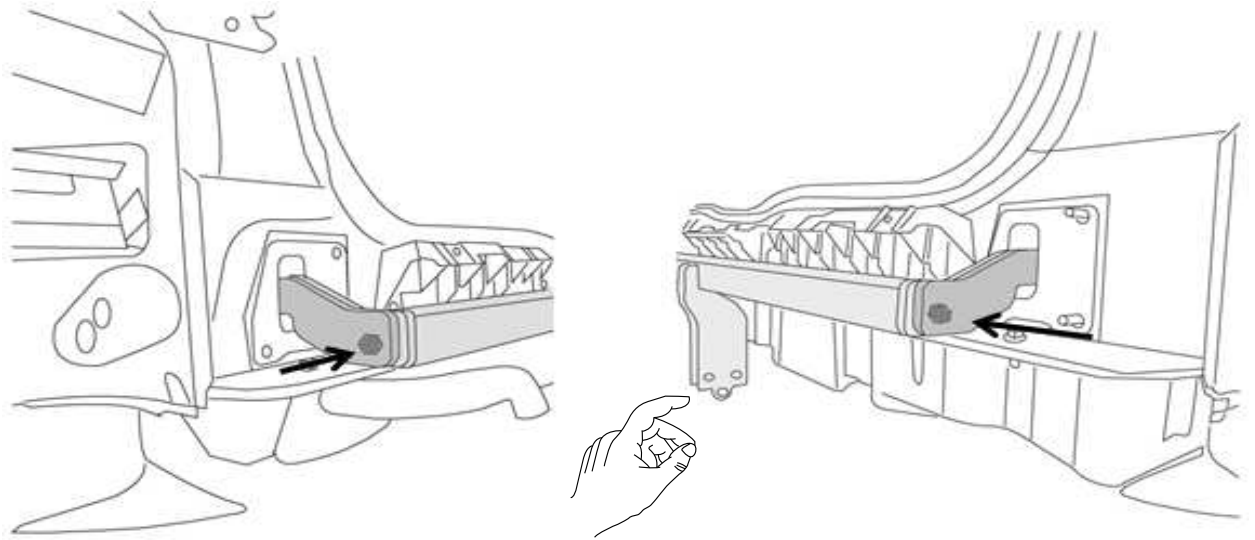

21

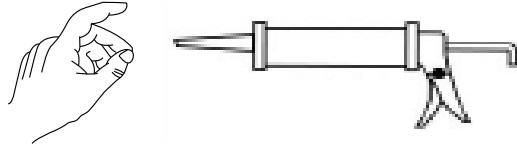
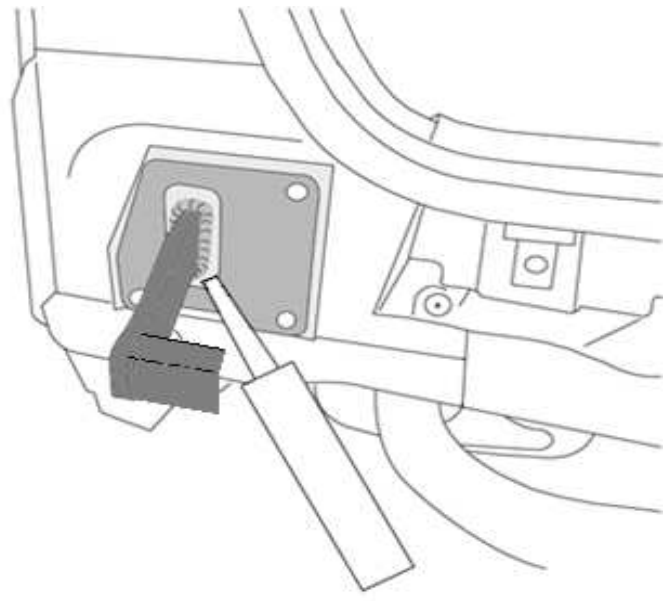
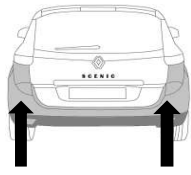

22

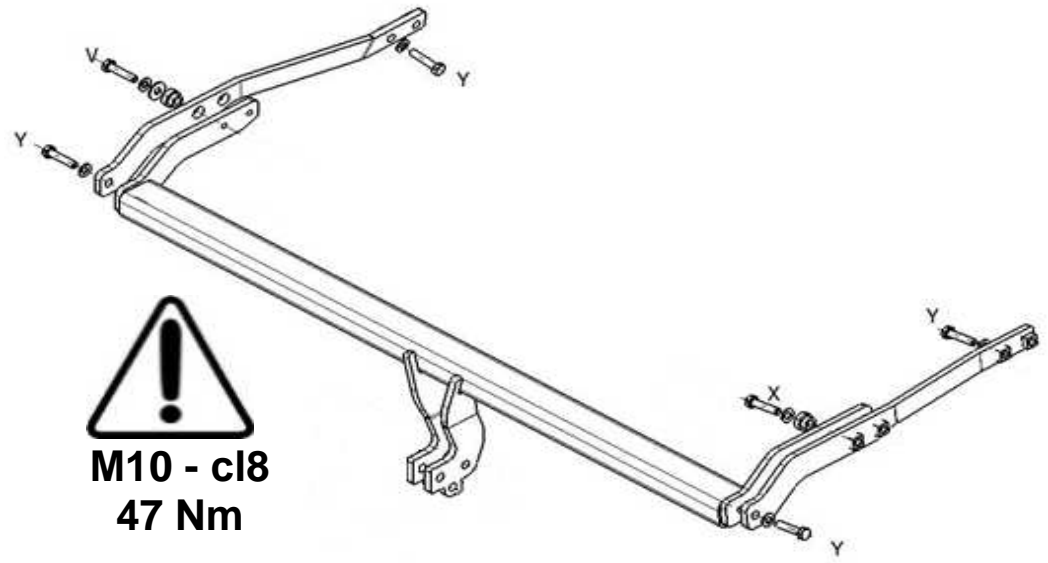

M10 - c18
47 Nm

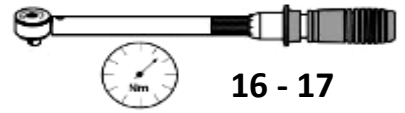

23



M8 - cl8
23 Nm

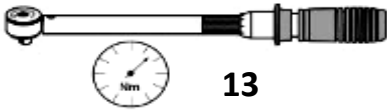
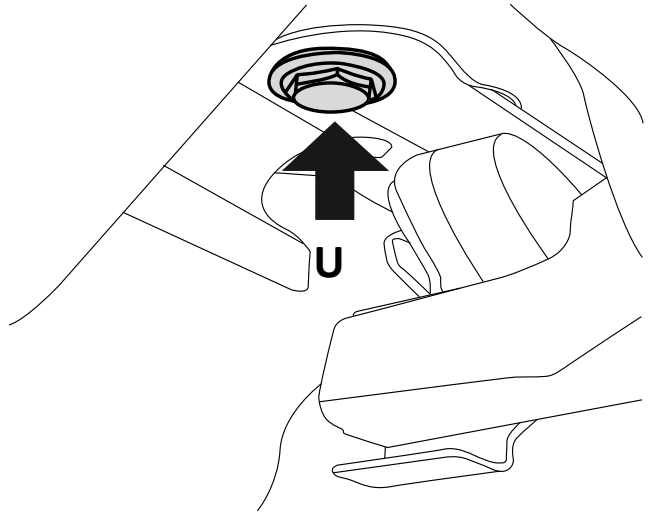

24

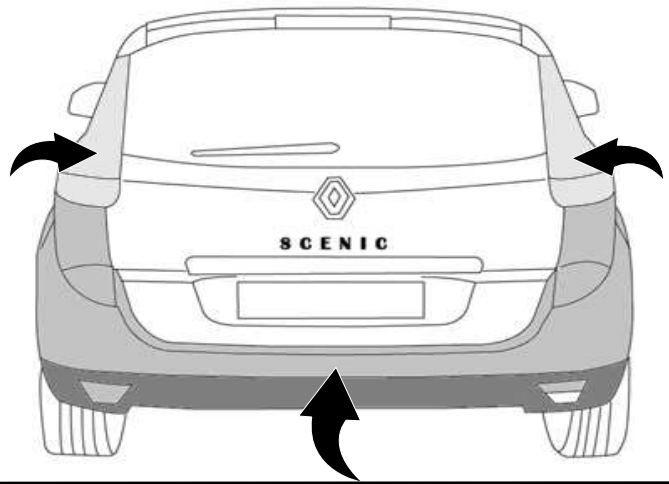
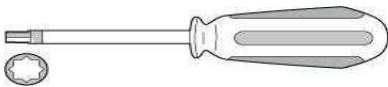

25



M12 - cl8
81 Nm

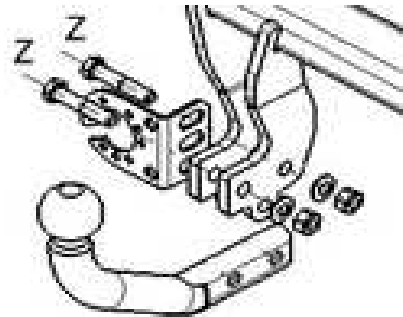
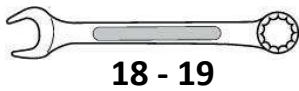
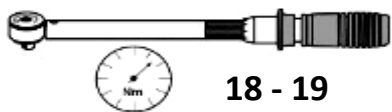

M12 - cl10
114 Nm

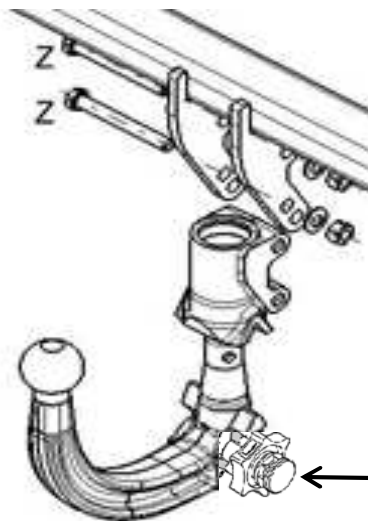
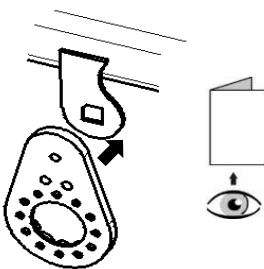

Dispositivo di traino tipo : **316352 - 316363**
Per autoveicolo : **Renault Mégane 2, Mégane 3 Scenic 2, Scenic 3**
Tipo funzionale : **BM - CM - SM - JM**
BZ - DZ - JZ..O



Classe e tipo di attacco : **A50-X**
Omologazione : **e24*55R*01 0322 (316352) - e24*55R*01 0321 (316363)**
Valore D : **8,67 kN**
Carico verticale max. S : **75 kg**
Massa rimorchiabile : vedi carta di circolazione dell'autoveicolo

In base alla Direttiva europea 94/20, la massa massima rimorchiabile del dispositivo di traino è determinata dal valore di prova "D" così definito :

$$D = (T \times C) / (T + C) \times 0,00981 = 8,67 \text{ kN}$$

dove : T = Massa complessiva max. della motrice (in kg) e C = Massa rimorchiabile max. della motrice (in kg)

DICHIARAZIONE DI CORRETTO MONTAGGIO :

la sottoscritta Ditta dichiara che il dispositivo di traino tipo _____ è stato installato a regola d'arte, nel rispetto dei punti d'attacco e delle prescrizioni fornite dalla Casa costruttrice

sul veicolo **Mégane 2 / Scenic 2 / Mégane 3 / Scenic 3**

targato _____

li _____

timbro et firma

Si dichiara inoltre di aver informato l'utente del veicolo sull'USO e MANUTENZIONE del dispositivo stesso.