

Assembly instructions tensioning pulley 531 0402 20

Manufacturer:

Audi, Skoda, Volkswagen

Engine: 2.5 TDI

Engine code: AFB, AKN, AYM, AKE,
BAU BDH, BCZ, BDG,
BFC

LuK AS Part No.: 531 0402 20

OE-No.: 059 109 243 D
059 109 243 J

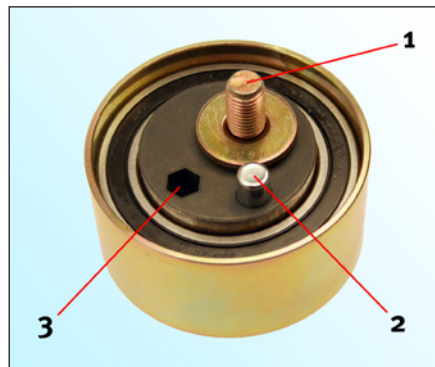

Fig 1: 531 0402 20 (rear view)

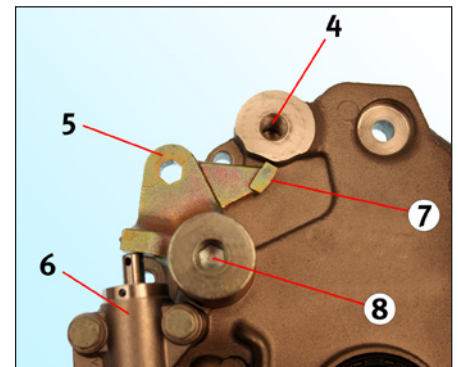

Fig 2: Cylinder block end plate

When carrying out work on the timing belt, ensure that the tensioning pulley **531 0402 20** located at the bottom of the drive belt is fitted correctly.



Incorrect assembly causes damage to the engine during operation! Observe the instructions from the manufacturer!

Legend:

- (1) Bolt for tensioning pulley
- (2) End stop
- (3) Hexagonal hole
- (4) Thread for fastening the tensioning pulley
- (5) Deflection lever
- (6) Hydraulic belt tensioner
- (7) Contact surface of the deflection lever
- (8) Pivot point of the deflection lever

When mounting the hydraulic belt tensioner (6) and the tensioning pulley, ensure that the end stop (2) of the tensioning pulley is positioned correctly (see **fig. 3** and **fig. 4** on **page 2**).

The end stop (2) must lie on the contact surface (7) of the deflection lever (5) during installation.

For further information:

Phone: +44 (0) 14 32 264 264*

Fax: +44 (0) 14 32 275 146

Info@LuK-AS.co.uk

www.Schaeffler-Aftermarket.com

* Calls from within the UK 08457 001100



Assembly instructions tensioning pulley 531 0402 20

Correct!

Fig. 3:
The end stop (2) of the tensioning pulley runs against the contact surface (7) of the deflection lever (5).

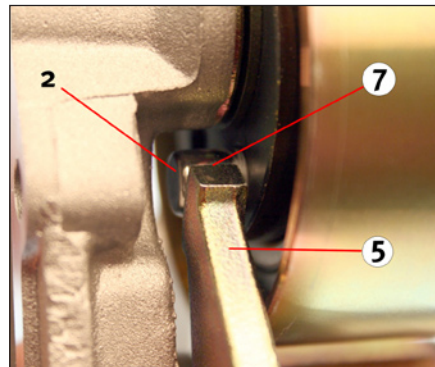

Fig. 3: Correct installation position (rear view)

Fig. 4:
The hexagonal hole (3) is positioned roughly at a right angle to the axis of the bolt (1) of the tensioning pulley and the pivot point (8) of the deflection lever (5) (see yellow orientation lines).

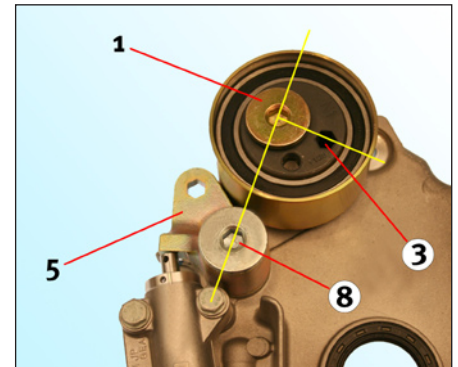

Fig. 4: Correct installation position (front view)

Wrong!

Fig. 5:
The end stop (2) of the tensioning pulley lies on the rear side of the deflection lever (5).

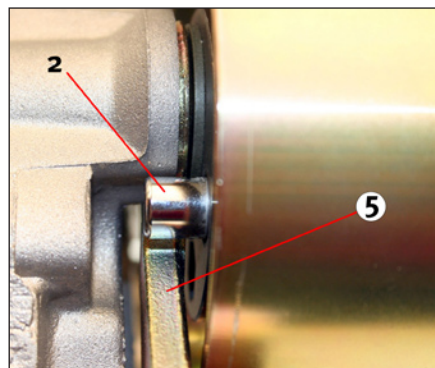

Fig. 5: Wrong installation position (rear view)

Fig. 6:
The hexagonal hole (3) is positioned in a straight line to the axis of the bolts, (1) the tensioning pulley and the pivot point (8) of the deflection lever (5) (see yellow orientation lines).

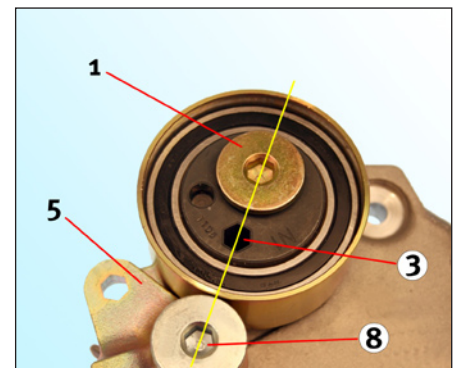

Fig. 6: Wrong installation position (front view)

Appropriate spare parts can be found in our on-line catalogue at www.Schaeffler-Aftermarket.com or at www.RepXpert.com.

Issued 11.2007
INA 0007

Technical subject to change
© 2007 LuK-Aftermarket Service oHG

For further information:

Phone: +44 (0) 14 32 264 264*

Fax: +44 (0) 14 32 275 146

Info@LuK-AS.co.uk

www.Schaeffler-Aftermarket.com

* Calls from within the UK 08457 001100

