

## Electric switch over valve for boost pressure control

si 0051 **GB**

### Complaint and fault diagnosis

#### Reduced or no power

MSI-PG 03.01

Vehicle: Audi / Ford / Seat / Skoda / VW				Product: Electr. switch over valve	
Type	Motor	Power (kW)	Engine-Code	Pierburg-No.	O.E.-No. *)
Variuss	1,9TDI	66	Variuss	7.21895.00.0	028 906 283F
			see	7.21895.13.0	028 906 283A
			TECDOC-CD	7.21895.30.0	028 906 283J
				7.21895.50.0	—
				7.21895.63.0	—
				<b>Replacement: 7.21895.55.0</b>	

### A. Boost pressure control with electric switch over valve, Fig. 1

In the case of TDI vehicles with boost pressure control on the exhaust side, a part of the exhaust gases is circulated around the turbine via a bypass, for pressure control purposes.

Used as a control device is a valve with flap or disk, the boost pressure control valve (waste gate). The valve is actuated via a diaphragm box, which is pressurised.

Boost pressure control takes place characteristic-dependent via the engine control unit.

For control purposes, the diaphragm of the boost pressure control valve is pressurised with control pressure via an **electric switch over valve**. The control pressure determines the opening cross-section of the boost pressure control valve and in turn the boost pressure.

The **electric switch over valve** functions as a timing valve; it is energised by the engine control unit with specific pulse duty factors (energised at various time intervals). Energisation of the valve produces the control pressure from the boost pressure and the pressure at the turbocharger inlet (roughly atmospheric pressure).

### B. Complaint and testing

The complaint **"reduced or no power"** can result due to the control unit changing to operation in the emergency program. In addition to faulty charge pressure control, a number of faults can result in the change to emergency operation. Faults of this type are stored.

In case of complaint, the fault memory should be read out and actuator diagnosis carried out. Apart from the V.A.G. 1551, there are also a number of suitable diagnostic or fault readout devices available.

The table below only contains the indications that can be displayed in the event of a faulty electric switch over valve. The indications appearing on standard displays may vary from those shown in the table.

Possible fault code and indication	Possible cause of fault	See chapter
<b>01262</b> Solenoid valve Boost pressure limiting N75 Interruption/ short-circuit to ground or positive	<ul style="list-style-type: none"> <li>Electric switch over valve faulty (AU/VW designation: N75)</li> <li>Cable break</li> <li>Short-circuit to ground or positive</li> </ul>	"C"
<b>00519</b> Sensor for intake pipe pressure -G71 Implausible signal	<ul style="list-style-type: none"> <li>Electric switch over valve faulty, leaky or sticks</li> <li>Hose connections interchanged, not connected</li> </ul>	"C" and Fig.1
<b>00575</b> Intake pipe pressure negative deviation		

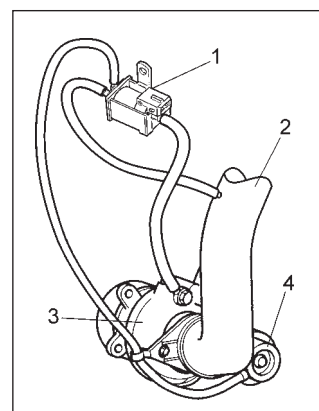

Fig. 1  
Boost pressure control connection diagram

- 1 Electric switch over valve
- 2 Air pipe from air filter
- 3 Turbocharger
- 4 Boost pressure control valve

Subject to changes and illustration!

\*) The listed reference numbers should be listed for comparison only. They may not be used on invoices sent to final users.

Subject to change of illustrations and text.

For changes with regard to respective matching and replacements, refer to the catalogs, TECDOC-CD or systems basing on TECDOC-data, which are currently in effect.

## C. Testing electric switch over valves

### Notes:

- It is recommended to first read out the fault memory and then carry out actuator diagnosis according to the instructions of the diagnostic unit manufacturer.
- An electric switch over valve activated through actuator diagnosis is energised at intervals, so that switching of the valve is noticeable.  
If switching of the valve is noticeable, the voltage supply and the electric switch over valve are electrically o.k.  
Leakage or internal fouling are not noticeable and must be checked as described in chapters 1.2 and 1.3.  
If switching of the valve is not noticeable, all of the tests listed below must be carried out.
- The electric switch over valve must be renewed, taking into account the enclosed information leaflet or si 0050.
- After testing and repair, the fault memory must be erased.

### 1. Testing electric switch over valve

#### 1.1 Electrical function

–Alternately apply external voltage (battery voltage) to the electric switch over valve.

**Required value:** Switching of the electric switch over valve must be noticeable.

If the required value is not reached, renew the electric switch over valve.

#### 1.2 Fouling (internal fouling)

–Check for fouling with a hand vacuum pump, Fig. 2.

**Required values:**

No voltage from connection 1 to 3  
Voltage from connection 2 to 3

If the required values are not reached, renew the electric switch over valve.

#### 1.3 Tightness

–Without voltage applied, connect hand vacuum pump to connection 2, Fig. 2 and apply a differential pressure of about 500 mbar.

**Required value:** No visible drop in differential pressure.

If the required value is not reached or a differential pressure build-up is not possible, replace the ECV.

### 2. Test on cable harness side

#### 2.1 Voltage supply

**Note:** The connector polarity can vary from vehicle to vehicle. The voltage supply is present at contact 1 or 2, Fig. 3. The other contact is intended for ground control purposes.

–Switch off ignition.

–Disconnect connector from electric switch over valve.

–Switch on ignition.

–Depending on vehicle, check voltage at connector contact 1 or 2, Fig. 3 and ground.

**Required value:** Battery voltage

If the required value is not reached, continue with test step 2.2.

#### 2.2. Testing cable connections to electric switch over valve

–Switch off ignition.

–Disconnect control unit connector from electric switch over valve.

–Test cables according to circuit diagram of vehicle manufacturer.

**a:** for open-circuit

**Required value:** max. 1.5  $\Omega$

**b:** for short-circuit between cables, to vehicle ground and battery positive

**Required value:**  $\infty \Omega$

If the system should fail to function despite the required values being reached, the control unit may be faulty.

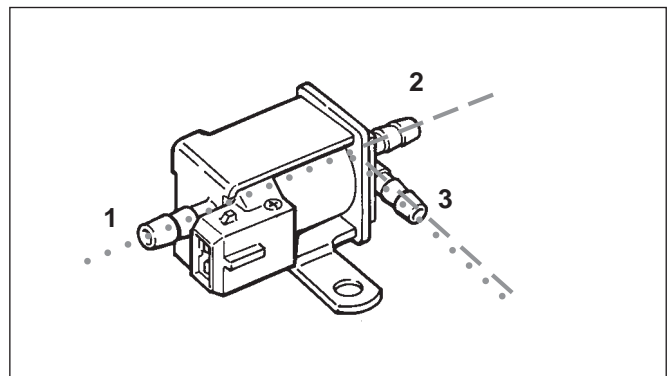

Fig. 2 Electric switch over valve

Technical data: Rated voltage: 12 V

Resistance:  $28.5 \pm 1.5 \Omega$

Operation: De-energised • • • • •

Energised — — —

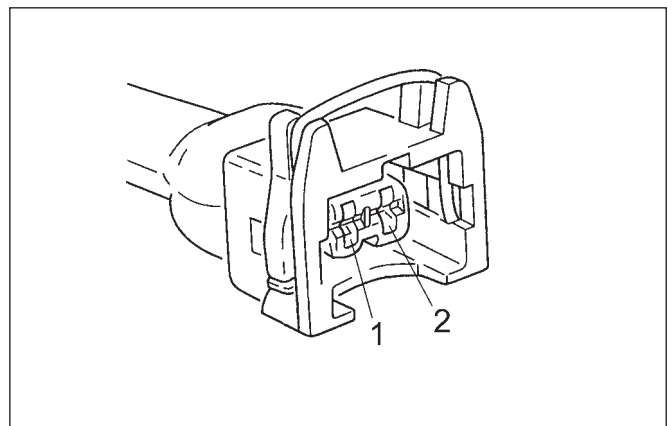

Fig. 3 Electric switch over valve connector