



The gearbox filter for all VW/AUDI 6-gear DSG gearboxes

VAICO-No.: V10-0440 suitable for OE: 02E 398 051

The twin-clutch DSG transmission developed by Volkswagen is deemed as one of the most significant technical innovations of the past years. It combines the comfort of an automatic transmission with the efficiency and dynamics of a manual transmission. Two clutches make sure that gears are changed within a matter of only a few hundredths of a second.

When changing gears, one clutch disengages while the other engages at the same moment. This is possible because the transmission preselects another gear when a gear is engaged.

Advantages vis-à-vis a conventional automatic transmission:

- No noticeable interruption of traction
- Pleasant driving experience
- Clearly higher efficiency factor
- Saves fuel, reduces CO2 emissions
- Manual gear change possible through Tiptronic transmissi

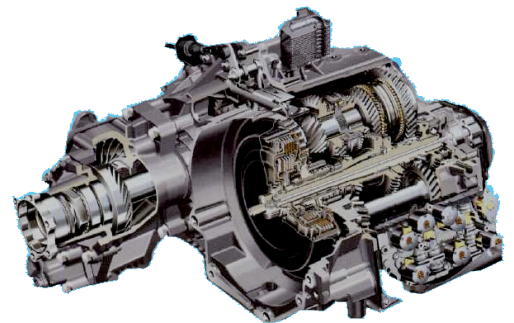

In the meantime every tenth Golf and every third Passat Variant is equipped with this transmission. The one millionth DSG transmission has been delivered by now.

Maintenance

To avoid damage to mechatronics systems, the VW/AUDI service plan prescribes a change interval of 60,000 km for the DSG gearbox oil as well as the DSG filter.

With its DSG oil change set VAICO offers the high-quality alternative to the OE.

VAICO DSG gearbox filter (incl. seal)

Art.-No.: V10-0440

Required quantity: 1

VAICO DSG gearbox oil

Art.-No.: V60-0118, 1 l

Required quantity: 6

